

# **BIRO**

## ***Our Equipment Works Harder So You Don't Have To***

The Biro Model AFMG-48 is a workhorse mixer grinder for the medium volume meat operation. Its 7.5 hp (5.6 kw) auger motor and size 32 head can give an output of over 65 pounds (30 kg) per minute for the productivity you need. Separate auger and mixer motors mean there is no clutch to wear out or break, which means much lower maintenance costs and higher profits. The single reduction heavy duty roller chain auger drive with tapered roller bearings is the most efficient drive system, so you get maximum power to the auger. The heavy duty stainless steel 200 pound (91 kg) hopper, frame, and legs can stand up to years of daily washdown and still resist corrosion, so your mixer grinder lasts longer and you get a better return on your investment. Power, durability, and low maintenance all help make the Biro AFMG-48 Mixer Grinder work harder so you don't have to.



# **AFMG-48**



*Stands alone for quality  
and value since 1921*

## SPECIFICATIONS

**MODEL** AFMG-48 MIXER GRINDER.  
**CONSTRUCTION** HEAVY DUTY STAINLESS STEEL HOPPER, LID, PADDLE, FRAME AND LEGS.  
 CAST IRON HOT TIN DIPPED BOWL, RING AND AUGER, SIZE 32.

**MOTORS**

| MOTOR | HP   | KW  | TYPE | VOLTS       | AMPS         | CYCLE | PH | STATUS |
|-------|------|-----|------|-------------|--------------|-------|----|--------|
| AUGER | 7.5  | 5.5 | TEFC | 208-230/460 | 24-21/11     | 60    | 3  | STD    |
| MIXER | 1.75 | 1.3 | TEFC | 208-230/460 | 5.7-5.5/2.6  | 60    | 3  | STD    |
| AUGER | 10   | 7.5 | TEFC | 208-230/460 | 31-27/14     | 60    | 3  | EC     |
| AUGER | 7.5  | 5.5 | TEFC | 575         | 8.8          | 60    | 3  | EC     |
| MIXER | 1.75 | 1.3 | TEFC | 575         | 2.4          | 60    | 3  | EC     |
| AUGER | 10   | 7.5 | TEFC | 575         | 11           | 60    | 3  | EC     |
| AUGER | 7.5  | 5.5 | TEFC | 220/380-415 | 22/12.7-12.4 | 50    | 3  | STD    |
| MIXER | 1.75 | 1.3 | TEFC | 220/380-415 | 5.9/3.4-3.1  | 50    | 3  | STD    |
| AUGER | 10   | 7.5 | TEFC | 220/380-415 | 28/16.2-14   | 50    | 3  | EC     |

TEFC= TOTALLY ENCLOSED FAN COOLED    STD=STANDARD  
 EC=EXTRA COST    NC=NO CHARGE

**SWITCH** WATERTIGHT MAGNETIC WITH THERMAL OVERLOAD AND UNDER VOLTAGE PROTECTION.

**POWER CORD** 12' 10-4 CORD WITH PLUG 7-1/2 HP, U.S., 12' 10-4 CORD NO PLUG 7-1/2 HP, 50 HZ AND 575 VOLT.  
 12' 8-4 CORD WITH PLUG 10 HP U.S., 12' 8-4 CORD NO PLUG 10 HP, 50 HZ AND 575 VOLT.

**CAPACITY** HOPPER 200 LBS. (91 KG).

**GRINDING CAPACITY** OUTPUT – UP TO 65 LBS. (30 KG) PER MINUTE.

**DRIVE SYSTEM** AUGER: SINGLE REDUCTION (35 PITCH – 4 ROW) ROLLER CHAIN DRIVE WITH TAPERED ROLLER BEARINGS.  
 MIXER: HEAVY DUTY COMBINATION GEAR MOTOR.

**SAFETY** MAGNETIC SAFETY INTERLOCK ON HOPPER LID.

**STANDARD FEATURES** 35 DEGREE RIGHT HAND INLET, STAINLESS STEEL 2ND GRIND PADDLE WITH CENTER ARMS, CASTERS, SPURT GUARD, EXTRA ROD FOR FRONT, LEFT OR RIGHT SIDE OPENING LID, POWER CORD (SEE ABOVE), RING WRENCH, BOWL NUT WRENCH, TWO SHEAR PINS WITH SCREWS, RECEPTACLE FOR ELECTRIC FOOTSWITCH, OPERATING AND SAFETY MANUAL.

**OPTIONS (EC)** ELECTRICAL OR PNEUMATIC FOOTSWITCH, SIZE 32 KNIVES AND PLATES, ACCESSORY CLEANING AND STORAGE RACK, EXTRA LONG STAINLESS STEEL LEGS (33"/838 MM TO 44"/1069 MM) FROM FLOOR TO BOWL CENTER, LEFT HAND 35 DEGREE SIDE INLET, LEFT OR RIGHT 90 DEGREE STRAIGHT SIDE INLET, CONNECTIONS FOR TANDEM OPERATIONS, 10 HP (7.5 KW) AUGER MOTOR, STAINLESS STEEL BOWL, RING AND AUGER (ENTERPRISE OR UNGER).

**OPTIONS (NC)** TUB WITH NO SIDE INLET (CALL FACTORY).

**CERTIFICATION** U.S.D.A., U.L., N.S.F., C.S.A.

**WEIGHT** UNCRATED: 720 LBS. (327 KG) APPROXIMATE.  
 CRATED: 830 LBS. (377 KG) APPROXIMATE.

**DIMENSIONS CRATED** L = 52" (130 CM), W = 35" (89 CM), H = 64" (163 CM).

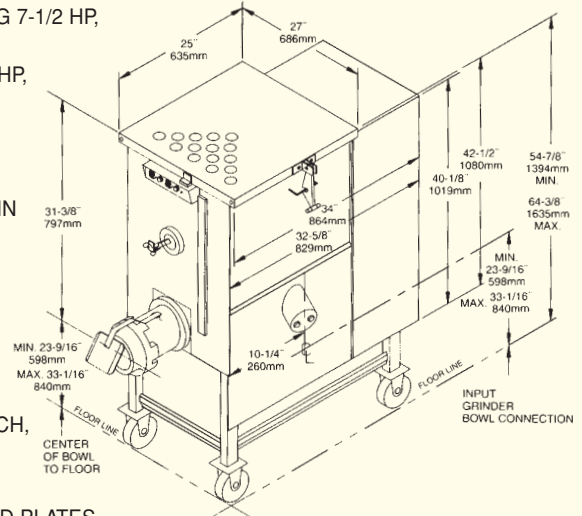

**THE BIRO MANUFACTURING COMPANY**  
**1114 WEST MAIN STREET**  
**MARBLEHEAD, OH 43440-2099 U.S.A.**  
**Phone: (419) 798-4451**  
**Fax: (419) 798-9106**  
<http://www.birosaw.com>  
**sales@birosaw.com**

ALL SPECIFICATIONS CONTAINED HEREIN ARE SUBJECT TO CHANGE WITHOUT NOTIFICATION.

ITEM NO.: LIT-AFMG48-123  
 FORM NO.: Md AFMG48-10-06-6-ENG-MARK

Service is available from over 245 locations worldwide